



Self-Recovery Winch

Thank you for purchasing a **COME UP Winch**. This manual covers operation and maintenance of the winch. All information in this publication is based on the latest production information available at the time of printing.

General Safety Precautions

A **COME UP** Winch is designed to give safe and dependable service if operated according to the instructions. Read and understand this manual before installation and operation of winch.

Follow these general safety precautions:

- Don't use unsuitable pulleys or accessories.
- Don't use unsuitable rope in construction, strength or having any defects.
- Check the winch for smooth operation without load before winching operation.
- Make sure the wire rope is wound evenly on the first layer on the drum, rewind it if not evenly wound.



1. The winch is rated for intermittent-periodic duty.
2. The winch is not to be used to lift, support or otherwise transport personnel.
3. A minimum of five (5) wraps of rope around the drum are necessary to support the rated load.
4. When choosing the right winch, you need to consider the vehicle size and weight. As a general guide, you need a winch with a maximum load rating of at least one and a half times greater than the gross vehicle weight.
5. The rated line pull of the winch must be powerful enough to overcome the added resistance caused by whatever the vehicle is stuck in.

I. Safety Precautions

Please read and understand this Instruction Manual before installing your winch.

- ⚠ Don't use unsuitable rope in construction, strength or having any defects.
- ⚠ Don't use unsuitable hook and pulley block for rope.
- ⚠ The operator of winch in some cases, is required to have qualifications according to applicable laws and ordinances.
- ⚠ Do not use winch as a lifting device or a hoist for vertical lifting .
- ⚠ Do not use winch to move people.
- ⚠ Do not exceed maximum line pull ratings shown in tables.

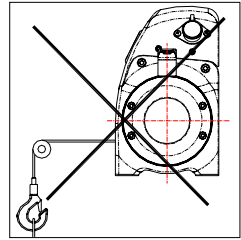

Shock load must not exceed these ratings.

- ⚠ Keep hands clear of wire rope and fairlead opening.
- ⚠ Pull from an angle below 15 degree to straighten up the vehicle or load.
- ⚠ Use leather gloves or a heavy rag when handling the wire rope.
- ⚠ When winching a heavy load lay a heavy blanket or jacket over the wire rope near the hook end.

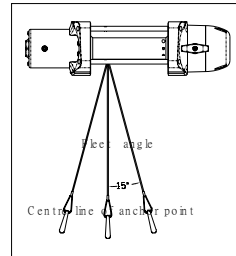

Load and speed vary according to how much wire rope is on the drum. The first layer of rope on the drum delivers the slowest speed and the maximum load. A full drum delivers the maximum speed and the minimum load. For this reason, winches are rated on their performance first layer of rope on the drum.

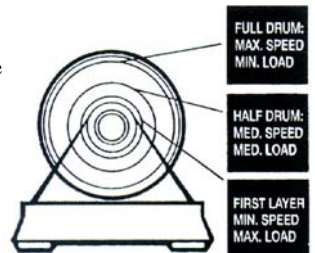

II. Performance Data

► Specifications

Model		DS-9.5	DS-9.5i
Line Pull (first layer)		4,309 kg / 9,500 lb	
Line Speed (first layer, no load)		19 mpm / 62.3 fpm	
Amp. Draw	12V	380 A	
	24V	250 A	
Motor	Type	Series wound	
	Output	12V	3,728 w / 5 hp
24V		2,240 w / 3 hp	
Gear Train	Type	3 stage planetary	
	Ratio	159 : 1	
Clutch		Rotating ring gear clutch	
Brake		Automatic full load cone brake	
Control		Detachable solenoid pack	Integrated solenoid pack
Wire Rope	Type	A7 x 19 Aircraft galvanized	
	Length	30 m / 100 ft	
	Size	8 mm / 5 / 16 in	

► Performance

Model		DS-9.5	DS-9.5i
1 st layer	Line pull (kg / lb)	4,309 / 9,500	
	Line speed (mpm / fpm)	2.12 / 7	
	Rope cap (m / ft)	6.1 / 20	
2 nd layer	Line pull (kg / lb)	3,521 / 7,750	
	Line speed (mpm / fpm)	2.6 / 8.5	
	Rope cap (m / ft)	13.5 / 44.3	
3 rd layer	Line pull (kg / lb)	2,977 / 6,550	
	Line speed (mpm / fpm)	3.07 / 10.1	
	Rope cap (m / ft)	22.3 / 73.2	
4 th layer	Line pull (kg / lb)	2,578 / 5,700	
	Line speed (mpm / fpm)	3.55 / 11.7	
	Rope cap (m / ft)	32.4 / 106.3	

► Line speed and Amp. Draw

At the first layer of wire rope on the drum.

Model		DS-9.5 / DS-9.5i			
Line Pull		Line Speed		Amp.	
Kg	lb	mpm	fpm	12V	24V
0	0	19	62	60	35
909	2,004	4.7	15.4	115	70
1,818	4,008	3.5	11.5	210	110
2,727	6,012	2.8	9.2	245	145
3,636	8,016	2.3	7.6	280	190
4,309	9,500	2.1	6.8	380	250

► Main Components

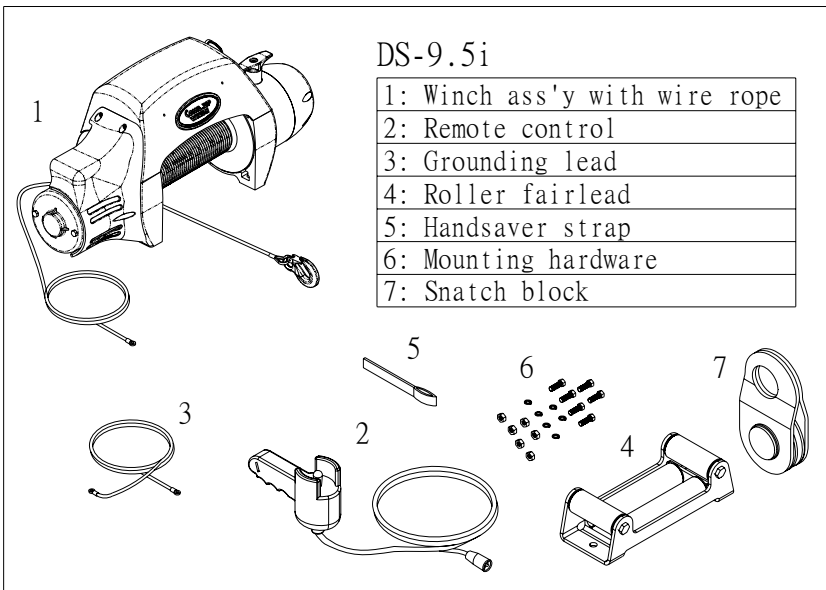
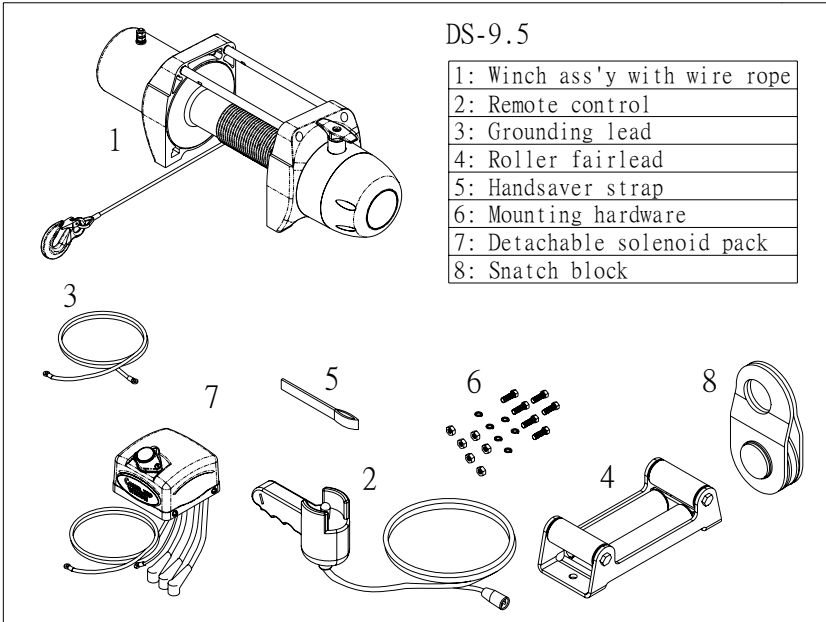

III. Installation

Before using the winch, make sure all electrical components have no corrosion or damaged; the environment should be clean and dry. The voltage drop from the battery connections to the winch must not exceed 10% of the nominal voltage under normal operating condition.

► Mounting

1. It is very important that the winch be mounted on a flat and hard surface in order to make sure the motor, drum and gearbox housing are aligned correctly.
2. It is recommended that you use a mounting channel to prevent from damaging winch or vehicle.
3. Four (4) M10 x 1.50 pitch 8.8 Grade High Tensile Steel Bolts must be used for fastening the winch into mounting channel in order to sustain the loads imposed on the winch mounting.
4. Two (2) M12 x 1.75 pitch 8.8 Grade High Tensile Steel Bolts must be used for fastening the roller fairlead into the mounting channel.

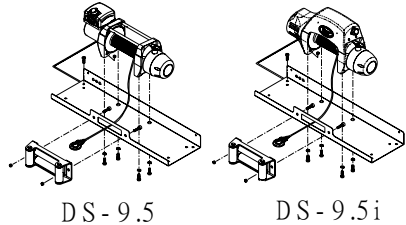

Foot print

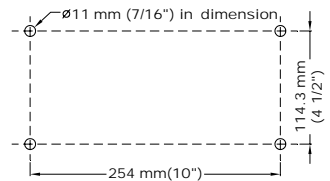

► Battery Lead Connection

Battery lead specification:

Model	DS-9.5	DS-9.5i
Control Type	Detachable solenoid pack	Integrated solenoid pack
Voltage	12V or 24V	Red cable: 2 AWG x 1.83 m / 72"
		Black cable: 2 AWG x 1.83 m / 72"

1. Attach the black lead (grounding) firmly to the negative (-) battery terminal.
2. Attach the red lead to the circuit breaker, connect the other end to the positive (+) battery terminal.
3. The circuit breaker shall be recommended to be fitted.

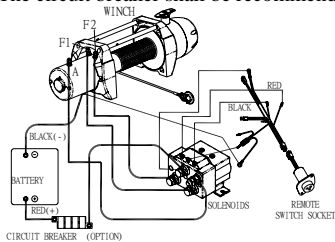

DS-9.5

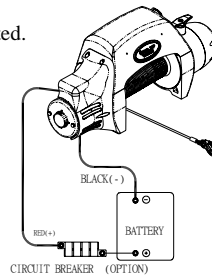

DS-9.5i

► Switch Connection

1. A trigger switch with $\phi 0.75$ mm X 6 C X 5 m (18 AWG X 6 C X 17') cord supplied
2. Open the dust-proof cover of the winch, then insert the switch plug into the socket.

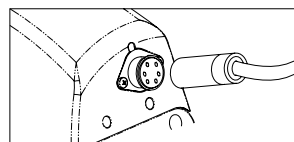

IV. Motor Temperature Indicator

► Protective thermal sensor LED

Green LED signal on the trigger switch and aluminium casting (for DS-9.5i only) shows the winch is operated under normal working condition.

Red LED signal shows on the trigger switch and aluminium casting (for DS-9.5i only) shows the winch is operated under abnormal working condition

If a winch which is operated with red LED signal for a long period will certainly result in damaged the winch. In this circumstance, you must power off the winch without delay.

DS-9.5

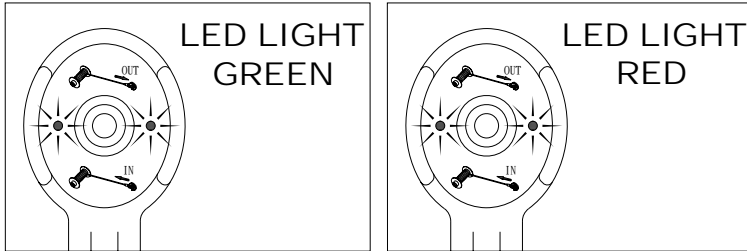

(Normal winching)

(Abnormal winching)

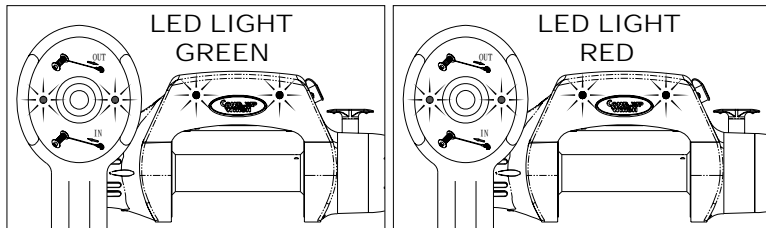

DS-9.5i

(Normal winching)

(Abnormal winching)

► Battery Recommendations

A fully charged battery and good connections are essential to the proper operation of your winch. The minimum requirement for a 12 volt DC battery is 650 cold cranking amp.

► Electrical Circuit Diagram

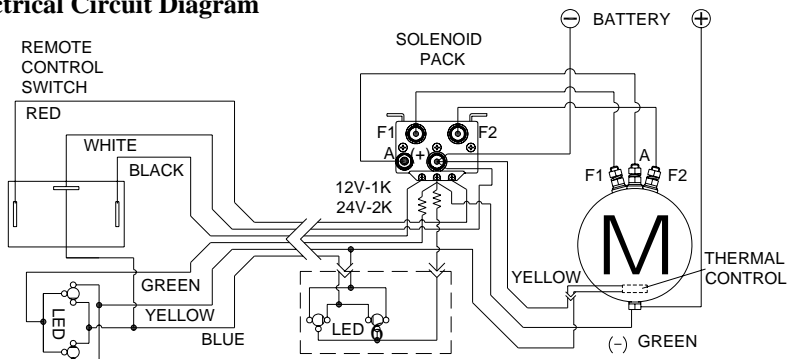

V. Operation

►Precautions

- ⚠ Check all safety and environmental conditions prior and during use.
- ⚠ A wire rope should be replaced if it shows signs of excessive wear, broken wires, corrosion or any other defects.
- ⚠ The operator must remain with the winch when it is being operated.
- ⚠ The winches duty rating is S3 (intermittent – periodic)
- ⚠ If the winch fails to pull a load under normal conditions, stop the operation within 30 seconds otherwise motor damage may occur.
- ⚠ Ensure that the winch is connected to the correct voltage. 12VDC or 24VDC only
- ⚠ Check that the clutch lever is in the “Engaged” position during and after use.
- ⚠ Remove the switch from the winch when not in use.
- ⚠ Do not wrap the wire rope around the load and back onto it self. Always use a strap to ensure that the wire rope does not fray or kink.
- ⚠ Keep hands and clothes away from the winch, wire rope, and fairlead.
- ⚠ Never unplug the pendant when winching a load.
- ⚠ Before use, ensure that you are familiar with all winching operations (winch speeds & direction).
- ⚠ To avoid insufficient power when winching a load, the vehicle should be running and in neutral.
- ⚠ Keep the switch cord clear of the wire rope at all times.
- ⚠ If noise or vibration occurs when running, stop the winch immediately and return it for repair.

►Cable-in/ Cable-out Operation

- 1). To determine “Cable - Out”, trigger → out
- 2). To determine “Cable - In”, trigger ← in

To stop winching, release the trigger

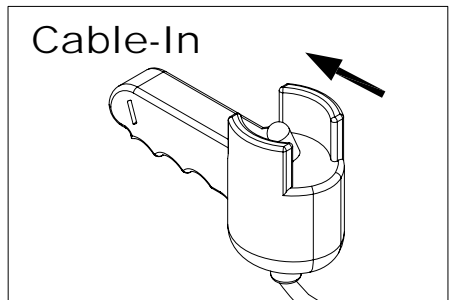
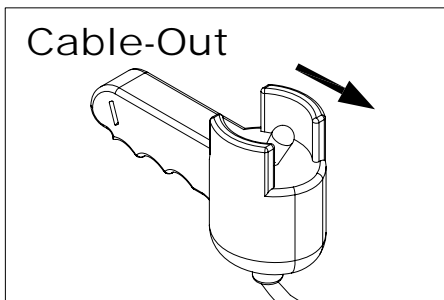

► Freespooling Function

The freespooling allows rapid payout of the wire rope for hooking onto a load or anchor points and is operated by the freespooling knob.

The freespooling knob must be in the “Engaged” position before winching.

- 1). To disengage the freespooling lift the freespooling knob up and turn it at 90° clockwise rotation to the “Disengaged” position, wire rope can now be free spooled off the drum.
- 2). To engage the freespooling lift the freespooling knob up and turn it at 90° counter-clockwise rotation to the “Engaged” position.
- 3). If a freespooling knob can’t be properly locked in the “Engaged” position, rotate the drum to make the freespooling coupled to the gear train.
- 4). Wear leather gloves and use a strap when guiding the wire rope off the drum.

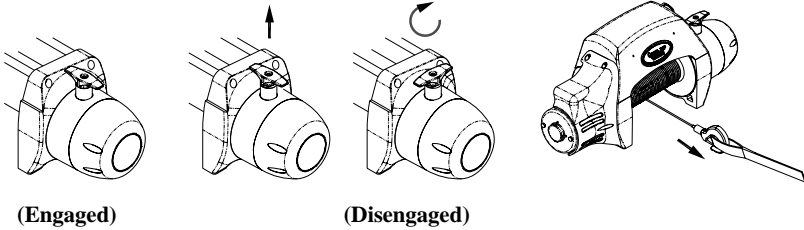

► Recovery Procedures

Followings are some safety tips to get out of trouble during a recovery.

- 1). Using a snatch block will increase the capacity, but the speed will decrease accordingly.
- 2). Experience has shown the best wire rope service is obtained when the maximum fleet angle is not more than 15 degree. Keep the wire rope as close as possible to the centre line of the anchor point.
- 3). It is the best to work with the most of wire rope unreeled from the drum to get more pulling power, but a minimum of five (5) wraps of wire rope should be wound around the drum to support the rated load.

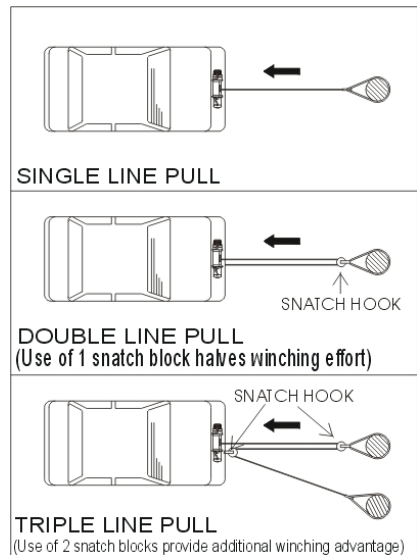

VI. Maintenance

► Cable Replacement

- Never use a rope of a different size or material and only use genuine replacement parts.
- If the winch is subjected to a high duty or excess load, the rope may require frequent replacement.

- 1). Disengage the freespooling.
- 2). Spool the entire wire rope, and then remove it from the drum.
- 3). Place the replacement wire rope through the fairlead opening, pass below the drum, and insert it into the hole on the drum core.
- 4). Tighten the screw downwards to secure the wire rope.

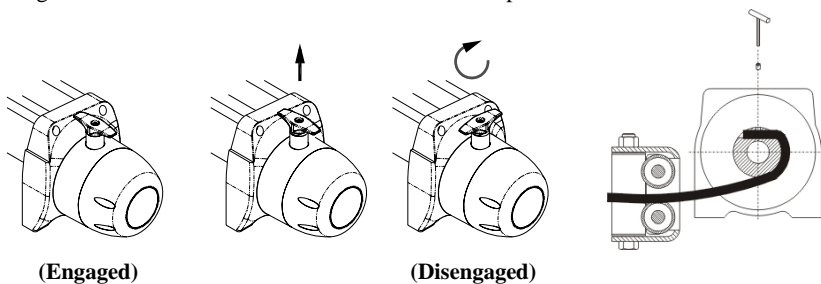

► Brake Adjustment

When the brake wears to the point that the load begins to slip. The brake can be adjusted as follows:

- 1). Loosen the bolt on the brake cover and take out c-rings
- 2). Insert few washers to maintain the brake spacer between to be 2.2 ± 0.25 mm
- 3). Make sure to keep the clutch base plate counter-clockwise by 150 – 180 degree

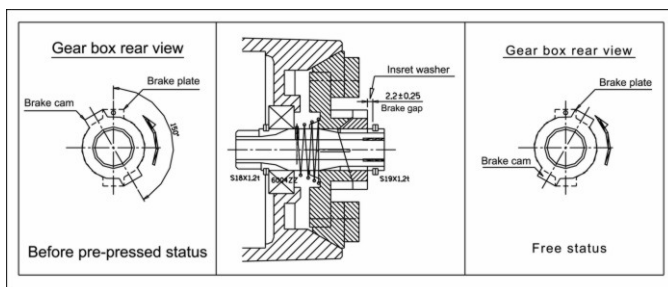

► Lubrication

All moving parts in the winch are permanently lubricated at the time of assembly. Under normal conditions factory lubrication will suffice. If re-lubrication is necessary after repair or disassembly use a marine type grease.

► Maintenance Schedule

- Ensure that a responsible person carries out all inspections as per schedule.
- Inspections are divided into Daily, Monthly and 3 Monthly.

Classification of check			Item	Checking method	Checking reference	
Daily	Periodical					
	One month	Three month				
○			Installation	Mounting bolts & alignment.	Bolt tension & wear.	Existence of abnormalities
○			Remote control	Working	Manual	Reasonable actuation
		○		Wearing in contact points	Visual.	Free of wear or damage.
○			Wire rope	Broken strands	Visual, measuring (monthly)	Less than 10%
○	○			Decrease in rope diameter	Visual, measuring (monthly)	7% of nominal diameter max
○				Deforming or corrosion	Visual	Existence of abnormalities
○				Fastening condition of end	Visual	Existence of abnormalities
		○	Freespooling	Wear in spring	Visual evidence of wear	Free of wear or damage.
		○	Motor	Staining, damage	Visual evidence of wear	Existence of abnormalities
		○	Brake	Wearing of lining	Visual evidence of wear	Free of wear or damage.
○				Performance	Visual	Reasonable actuation
		○	Gear	Damage, wearing	Visual evidence of wear	Free of wear or damage.

VI. Trouble Shooting

When the winch fails to operate after several attempts, or if there is any fault while

Symptom	Possible Cause	Remedy
Winch will not operate	Cut circuit	Check battery lead.
	Weak battery	Recharge or replace battery (at least 650CCA)
	Damaged over-load protector(option)	Replace over-load protector(option)
	Bad connection of wirings	Reconnect tightly
	Damaged solenoid	Replace solenoid
	Cut circuit on switch	Replace switch
	Damaged motor or worn carbon brush.	Replace motor or carbon brush
Motor runs in one direction.	Dropt or lost motor wirings.	Replace wirings or tight it.
	Broken wirings or bad connections	Reconnect or replace wirings
	Damaged or stuck solenoid	Replace solenoid
	Switch inoperative	Replace switch
Drum will not free spool.	Dropt or lost wirings.	Replace wirings and tighten.
	Freespooling not disengaged	Engaged Freespooling
	Damaged 1st shaft	Replace 1 st shaft
	Damaged brake cam and disc	Replace brake cam and disc
No brake	Damaged output shaft	Replace output shaft
	Damaged brake cam and disc	Replace brake cam and disc
	Damaged gear box	Replace gear box
	Dropt snatch ring	Replace snatch ring
Brake distance is too long	Oil leakage at brake	Clean oil leakage
	Damaged or inoperative spiral spring	Replace and position spiral spring
	Worn or damaged brake	Replace or adjust brake
Brake will be locked	Oil leakage at brake.	Clean oil leakage
	Too much brake powder	Clean brake ass'y
	Over pre-pressed spiral spring	Adjust pre-pressed spiral spring
Damaged gear box	Stuck between brake lining and gear box	Replace a new winch
	Hit by certain exterior force.	Replace the damaged components
	Damaged gear train.	Replace the damaged components
Motor runs extremely hot	Over load operation.	Replace a new winch
	Long period of operation	Allow to cool
	Damaged motor	Replace or repair motor
	Damaged or inoperative brake	Replace or repair brake

operating check the following:

VIII. Replacement parts List

►DS-9.5

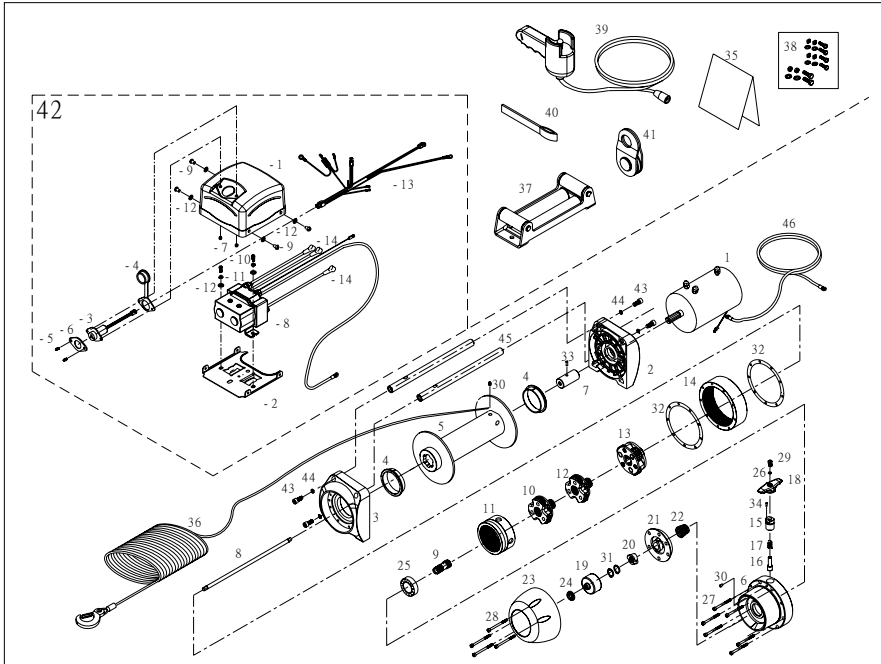

No.	Description	Q'ty	No.	Description	Q'ty	No.	Description	Q'ty
1	Motor	1	22	Spiral spring	1	-1	Control box upper cover	1
2	Motor support rack	1	23	Brake cover	1	-2	Control box base cover	1
3	Gear support rack	1	24	Bearing	1	-3	Remote switch socket	1
4	Drum bushing	2	25	Bearing	1	-4	Rubber cover	1
5	Drum	1	26	Spring washer	1	-5	Round cross bolt	2
6	Gear box	1	27	Hex. bolt	6	-6	Socket plate	1
7	Connecting socket	1	28	Hex. bolt	4	-7	Nut	2
8	1 st shaft	1	29	Hex. lockbolt	1	-8	Solenoid pack	1
9	1 st pinion	1	30	Hex. bolt	1	-9	Cross bolt	4
10	1 st stage carrier	1	31	Retaining ring	2	-10	Cross bolt	2
11	1 st & 2 nd ring gear	1	32	Gasket	2	-11	Spring washer	2
12	2 nd stage carrier	1	33	Spring pin	1	-12	Dented washer	6
13	3 rd stage carrier	1	34	Spring pin	1	-13	Control cord B	1
14	3 rd ring gear	1	35	Foot print	1	-14	Cable tube	3
15	Freespooling sleeve	1	36	Wire rope	1	43	Hex. bolt	4
16	Freespooling lever	1	37	Roller fairlead	1	44	Spring washer	4
17	Compression spring	1	38	Mounting hardware		45	Tie bar	2
18	Freespooling knob	1	39	Remote control	1	46	Grounding cable	1
19	Brake Freespooling base	1	40	Handsaver strap	1	47		
20	Brake cam	1	41	Snatch block	1	48		
21	Cone brake disc	1	42	Detachable solenoid pack	1	49		

►DS-9.5i

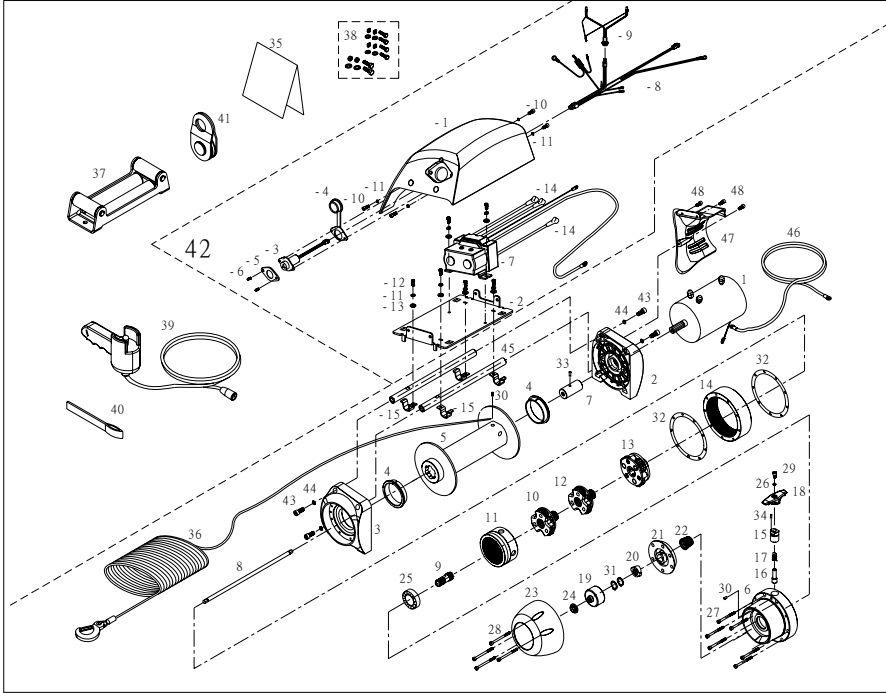

No.	Description	Q'ty	No.	Description	Q'ty	No.	Description	Q'ty
1	Motor	1	22	Spiral spring	1	-1	Control box upper cover	1
2	Motor support rack	1	23	Brake cover	1	-2	Control box base cover	1
3	Gear support rack	1	24	Bearing	1	-3	Remote switch socket	1
4	Drum bushing	2	25	Bearing	1	-4	Rubber cover	1
5	Drum	1	26	Spring washer	1	-5	Round cross bolt	1
6	Gear box	1	27	Hex. bolt	6	-6	Switch socket plate	1
7	Connecting socket	1	28	Hex. bolt	4	-7	Solenoid pack	1
8	1 st shaft	1	29	Hex. lockbolt	1	-8	Control cord B	1
9	1 st pinion	1	30	Hex. bolt	1	-9	LED	1
10	1 st stage carrier	1	31	Retaining ring	2	-10	Hex. bolt	7
11	1 st & 2 nd ring gear	1	32	Gasket	2	-11	Spring washer	10
12	2 nd stage carrier	1	33	Spring pin	1	-12	Cross bolt	6
13	3 rd stage carrier	1	34	Spring pin	1	-13	Dented washer	6
14	3 rd ring gear	1	35	Foot print	1	-14	Cable Tube	3
15	Freespooling sleeve	1	36	Wire rope	1	-15	Clamp	4
16	Freespooling lever	1	37	Roller fairlead	1	43	Hex. bolt	4
17	Compression spring	1	38	Mounting hardware		44	Spring washer	4
18	Freespooling knob	1	39	Remote control	1	45	Tie bar	2
19	Brake Freespooling base	1	40	Handsaver strap	1	46	Grounding cable	1
20	Brake cam	1	41	Snatch block	1	47	Motor side cover	1
21	Cone brake disc	1	42	Integrated solenoid pack	1	48	Hex. bolt	3

Limited Warranty

This Limited Warranty is given by the Comeup Industries Inc. (the “Seller”) to the original purchaser (the “Purchaser”) of a **COMEUP Winch** specified in this manual. This Limited Warranty is not transferable to any other party.

The Seller takes the responsibility for all parts and components, with the exception of the wire rope, to be free from defects in materials and workmanship appearing under normal use for as long as the said Purchaser owns the vehicle that the winch was originally mounted on. Electrical components are warranted for 1 Year from date of purchase under the same conditions. Any **COMEUP Winch**, which is defective, will be repaired or replaced without charge to the Purchaser.

Upon discovering any defect, the Purchaser under this Limited Warranty is requested to return the complete winch and inform the seller or their authorised distributors of any claims. The Purchaser must provide a copy of the proof of purchase bearing the winch serial number, date of purchase, owners name and address, vehicle details and registration number.

The Limited Warranty does not cover any failure that results from improper installation, operation or the Purchaser’s modification in design. The winch is designed for vehicle self-recovery use only and should not be used in industrial applications or for moving people. The Seller does not warrant them to be suitable for such use.